

# MILLIKEN<sup>®</sup>

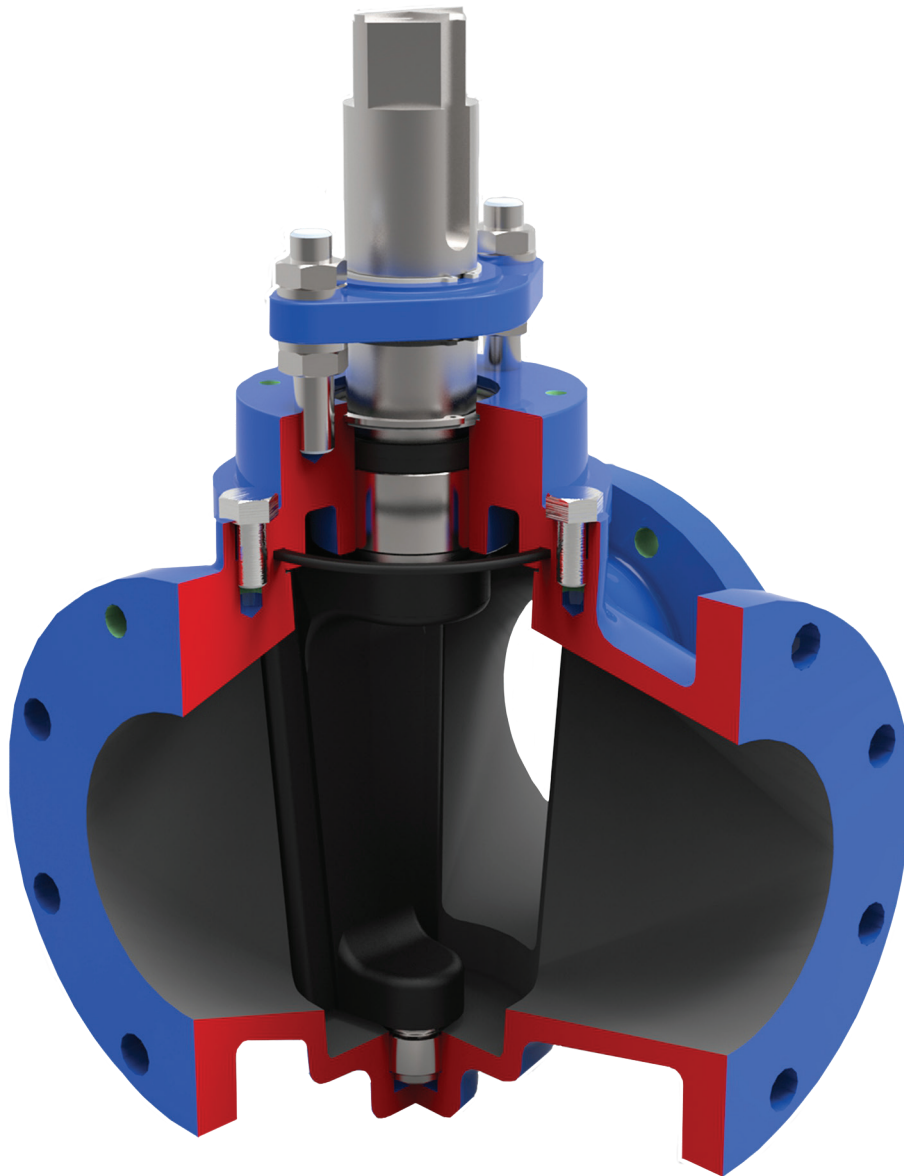

**MILLCENTRIC<sup>®</sup>**  
**100% Port 3-WAY PLUG VALVE**

# Milliken® Millcentric® 100% Port 3-way Plug Valve

Quality, reliability, safety and value are the criteria embodied in the Millcentric 100% Port 3-Way plug valve.

High quality manufacturing processes from advanced CAD engineering to CNC machining ensure reliable operation with high flow capability.

The Millcentric 100% Port 3-Way plug valve is designed for regulation, diversion and isolation of water (clean or dirty) and sludge and slurries. The single tapered plug design can be arranged to provide a wide selection of flow configurations.

High flow and large solids passage is a key feature of the Millcentric 100% Port 3-Way valve; a 3" round solid can pass through a 4" valve without compression.

Although the regular usage of a Millcentric 3-Way valve is for flow diversion applications, the valve can provide tight shut-off, which is factory set when requested at order placement. (Not available with double-style plug or on 14" and 16" valves).

## Body & Seat

The Millcentric 3-Way valve body is a high integrity casting in cast iron ASTM A126 Class B. The precision machined, internal tapered surface of the body is the valve seat which is provided with a corrosion and erosion resistant epoxy coating. Other materials are available.

## End Connections

The 3-flanges are to ASME/ANSI B16.1 Class 125 flat faced.

Certain sizes of valve require some tapped bolt holes because of limited access for nuts behind the flange, details are shown on page 5.

## Plug

The ductile iron plug is totally encapsulated (3" thru 12") with a molded and vulcanized elastomer providing sealing and tight shut-off. For tight shut-off applications, it is advisable that the flow is against the rear of the plug. Tight shut-off not available with double-style plug or on 14" and 16" valves.

A large-diameter stem and upper and lower trunnion are integral with the plug casting. The upper end of the stem has a 2" square drive for wrench operation and also 2 keyways for maximum versatility when mounting gear operators. A cast marking on the end of the shaft indicates the plug face orientation.

The single style plug is standard in the Millcentric 3-Way valve to provide straight-through and 90° flow paths. A double-style plug is optionally available upon request (not tight shut-off).

## Bearings

The plug rotates in permanently lubricated, corrosion resistant stainless steel bearings in the body and bonnet.

## Bonnet Seal

The bolted bonnet is assembled in a precision location in the body and uses superior 'O'-Ring sealing, with metal to metal contact, providing lower stress compared to traditional gaskets.

## Stem Seal

Multiple self-adjusting U-cup seals provide positive stem sealing with trouble-free service.

## Operation

Manual operation by lever or gear available on all sizes. Chainwheel operation is also available.

Electric or pneumatic actuation is available on request.

## Coating

The valve interior and exterior surfaces are coated with 10-12 mils of 2-Part epoxy.

## Available Flow Paths

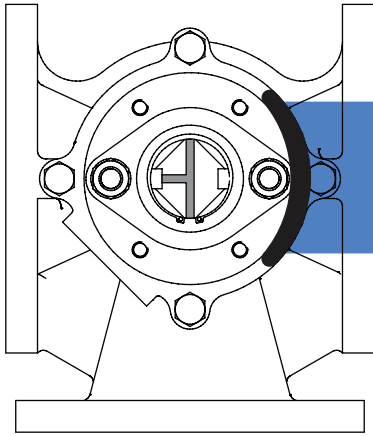

Valve in closed position\*

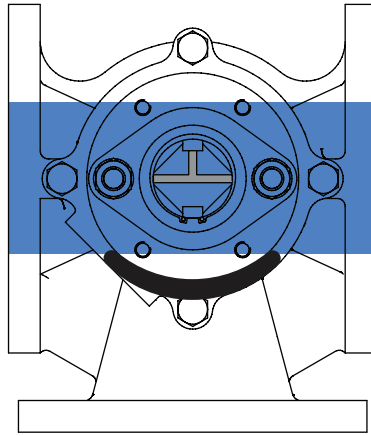

Flow straight through valve

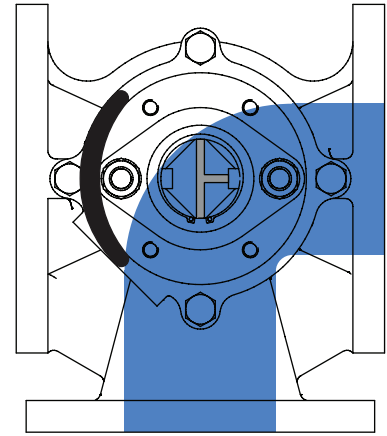

Flow through 90° to side port

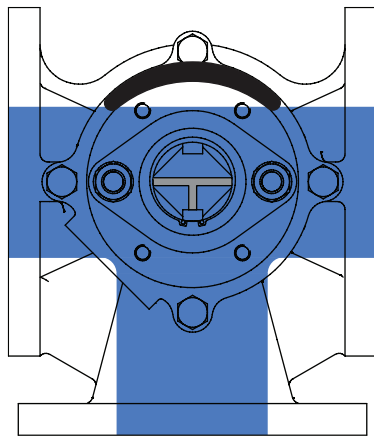

All 3 ports connected and open

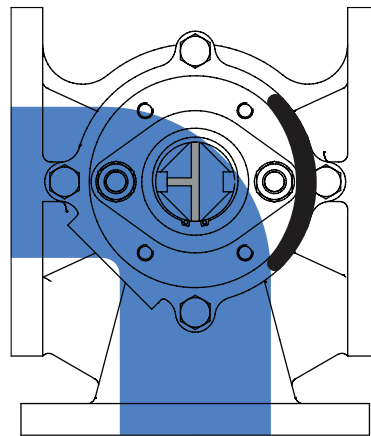

Flow through 90° to side port

\*It is advisable that the flow is against the rear side of the plug for tight shut-off applications. Not available with double-style plug.

### Pressure/Temperature ratings

Flange rating to ASME/ANSI B16.1 Class 125, the maximum cold working pressure for all sizes is 175psi.

The operating temperature of the valve may depend on the elastomer used for the plug and seals. Refer to the elastomer selection guide on page 4.

### Installation

The Millcentric® 3-Way valve can be installed in any orientation although it is advisable to have the valve stem vertical for ease of access.

If the valve has been supplied for tight shut-off, the flow path and therefore the upstream pressure should be against the rear side of the plug.

### In-Line Maintenance

In the unlikely event of gland leakage, the stem seals can be replaced without removing the bonnet. Access to the inside of the body for inspection or cleaning does not require removal of the valve from the line.

If wear should occur between the plug face and the seat, the plug can be adjusted externally.

# Standard Materials of Construction - 3" to 16"

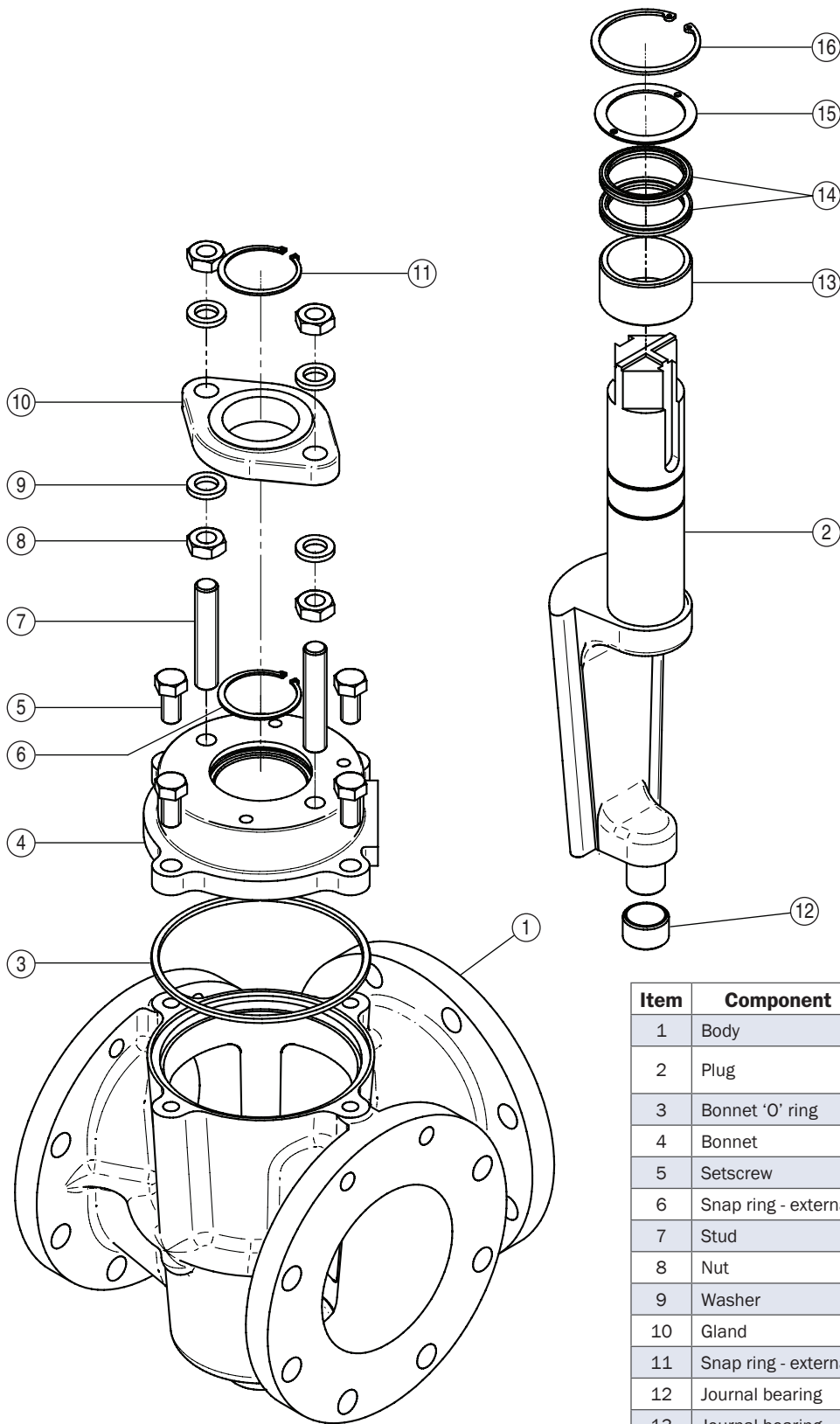

Item	Component	Material
1	Body	Cast iron A126 Class B
2	Plug	Ductile iron ASTM A536 Rubber coated
3	Bonnet 'O' ring	Elastomer as specified
4	Bonnet	Cast iron A126 Class B
5	Setscrew	Steel - zinc plated
6	Snap ring - external	Steel
7	Stud	Steel - zinc plated
8	Nut	Steel - zinc plated
9	Washer	Steel - zinc plated
10	Gland	Ductile iron ASTM A536
11	Snap ring - external	Steel
12	Journal bearing	Stainless Steel
13	Journal bearing	Stainless Steel
14	'U' cup seal	Elastomer as specified
15	Seal retaining ring	Brass
16	Snap ring - internal	Steel

# Elastomers Available for Millcentric® 100% Port 3-Way Valves

## • NBR - Nitrile

A general purpose material sometimes referred to as BUNA N with a temperature range -20°F to 212°F. Used on sewage, water, air, hydrocarbon and mineral oils.

## • EPDM

An excellent polymer for use on chilled water through to LP steam applications, having a temperature range of -20°F to 250°F. Resistance to many acids, alkalies, detergents, phosphate esters, alcohols and glycols is an added benefit. Use on hydrocarbons must be avoided.

## • CR - Neoprene

This versatile material shows outstanding resistance to abrasion and ozone. Chemical resistance to a wide range of petroleum based products and dilute acids and alkalies. Temperature range -20°F to 225°F.

## • FKM - Viton®

Retention of mechanical properties at high temperature is an important feature of this elastomer: temperature range is -10°F to 300°F. It also has excellent resistance to oils, fuels, lubricants and most mineral acids and aromatic hydrocarbons. NOT suitable for water or steam applications.

## Pressure Rating

Size	Drilling	Pressure
3" to 16"	Class 125	175 psig

Body (Shell) Hydrotest = 1.5 x rated pressure

Seat hydrotest = 1.0 x rated pressure (for tight shut-off applications only)

## Ordering Information

Valve Types	Designation
Class 125 Flanged Cast Iron	604
Class 125 Flanged Ductile Iron	614
Class 125 Flanged 316 Stainless Steel	604S

## Seat

Epoxy (604/614)	E
Stainless Steel (604S)	S

## Elastomer Trim

EPDM	0
Nitrile (Buna)	1
Viton	2
Neoprene	3

## Gear Operators

Gearbox complete with handwheel AGHW  
Available in 90°, 180°, 270° and 360° configurations.

## Style

Available port positions as shown on page 8.

The style can be factory set and should be requested at time of order.

## • Elastomer Selection Chart

Service	Elastomer	Average Useful Temperature Range	Service	Elastomer	Average Useful Temperature Range	Service	Elastomer	Average Useful Temperature Range
Acetone	EPDM	-35° F to 250° F	Copper Sulphate	EPDM	-35° F to 250° F	Oil Mobil Therm 600	Viton	10° F to 250° F
Alcohol, Amyl	EPDM	0° F to 212° F	Creosote (Coal)	Nitrile	-20° F to 212° F	Oil Mobil Therm 603	Nitrile	-20° F to 212° F
Alcohol, Aromatic	Viton	10° F to 250° F	Coal Slurry	Nitrile	-20° F to 212° F	Oil Lubricating	Nitrile	-20° F to 212° F
Alcohol, Butyl	Neoprene	-20° F to 225° F	Diesel Fuel No. 3	Nitrile	-20° F to 212° F	Oil Vegetable	Nitrile	-20° F to 212° F
Alcohol, Denatured	Nitrile	-20° F to 212° F	Diethylene Glycol	EPDM	-35° F to 250° F	Paint Latex	Nitrile	-20° F to 212° F
Alcohol, Ethyl	EPDM	-35° F to 250° F	Ethylene Glycol	EPDM	-35° F to 250° F	Phosphate Ester	EPDM	-35° F to 250° F
Alcohol, Grain	Nitrile	-20° F to 212° F	Fatty Acid	Nitrile	-20° F to 212° F	Propane	Nitrile	-20° F to 212° F
Alcohol, Isopropyl	Neoprene	-20° F to 225° F	Fuel Oil No. 2	Nitrile	-20° F to 212° F	Rape Seed Oil	EPDM	-35° F to 250° F
Alcohol, Methyl	EPDM	-35° F to 250° F	Fertilizer Liquid (H <sub>4</sub> N <sub>2</sub> O <sub>2</sub> )	EPDM	-35° F to 250° F	Sewage with Oil	Nitrile	-20° F to 212° F
Ammonia, Anhydrous	Neoprene	-20° F to 225° F	Gasoline Keg	Nitrile	-20° F to 212° F	Sodium Hydroxide 20%	EPDM	-35° F to 250° F
Ammonia, Nitrate	EPDM	-35° F to 250° F	Gas Natural	Nitrile	-20° F to 212° F	Starch	EPDM	-35° F to 250° F
Ammonia, Water	EPDM	-35° F to 250° F	Glue Animal	Nitrile	-20° F to 212° F	Steam 250° F	EPDM	-35° F to 250° F
Animal Fats	Nitrile	-20° F to 212° F	Green Liquor	EPDM	-20° F to 212° F	Stoffard Solvent	Nitrile	-20° F to 80° F
Black Liquor	EPDM	-35° F to 250° F	Hydraulic oil	Nitrile	-20° F to 212° F	Sulphuric Acid 10% 50%	Neoprene	-20° F to 158° F
Blast Furnace Gas	Neoprene	-20° F to 225° F	Hydrogen	Nitrile	-20° F to 212° F	Sulphuric Acid 100%	Viton	10° F to 300° F
Butane	Nitrile	-20° F to 212° F	JP4 JP5	Viton	-20° F to 212° F	Trichlorethylene Dry	Viton	10° F to 300° F
Bunker Oil "C"	Nitrile	-20° F to 212° F	Kerosene	Nitrile	0° F to 212° F	Triethanol Amine	EPDM	-35° F to 250° F
Calcium Chloride	EPDM	-35° F to 250° F	Ketone	EPDM	-35° F to 250° F	Varnish	Viton	10° F to 300° F
Carbon Dioxide	EPDM	-35° F to 250° F	Lime Slurry	EPDM	-35° F to 250° F	Water, Fresh	EPDM	-35° F to 250° F
Carbon Monoxide (Cold)	Neoprene	-20° F to 150° F	Methane	Nitrile	-20° F to 212° F	Water, Salt	EPDM	-35° F to 250° F
Carbon Monoxide (Hot)	Viton	10° F to 300° F	Methyl Ethyl Ketone	EPDM	-35° F to 250° F	Xylene	Viton	10° F to 300° F
Carbon Tetrachloride	Viton	10° F to 300° F	Naptha (Berzin)	Nitrile	-20° F to 212° F			
Caustic Soda	EPDM	-35° F to 250° F	Oil Animal	Nitrile	-20° F to 212° F			
Cement Slurry	EPDM	-35° F to 250° F	Oil Mobil Therm Light	Viton	10° F to 250° F			

NOTE: Above elastomer/temperature chart are guidelines only. Contact factory for specific applications.

# Series 604 Millcentric® 100% Port 3-Way Plug Valve

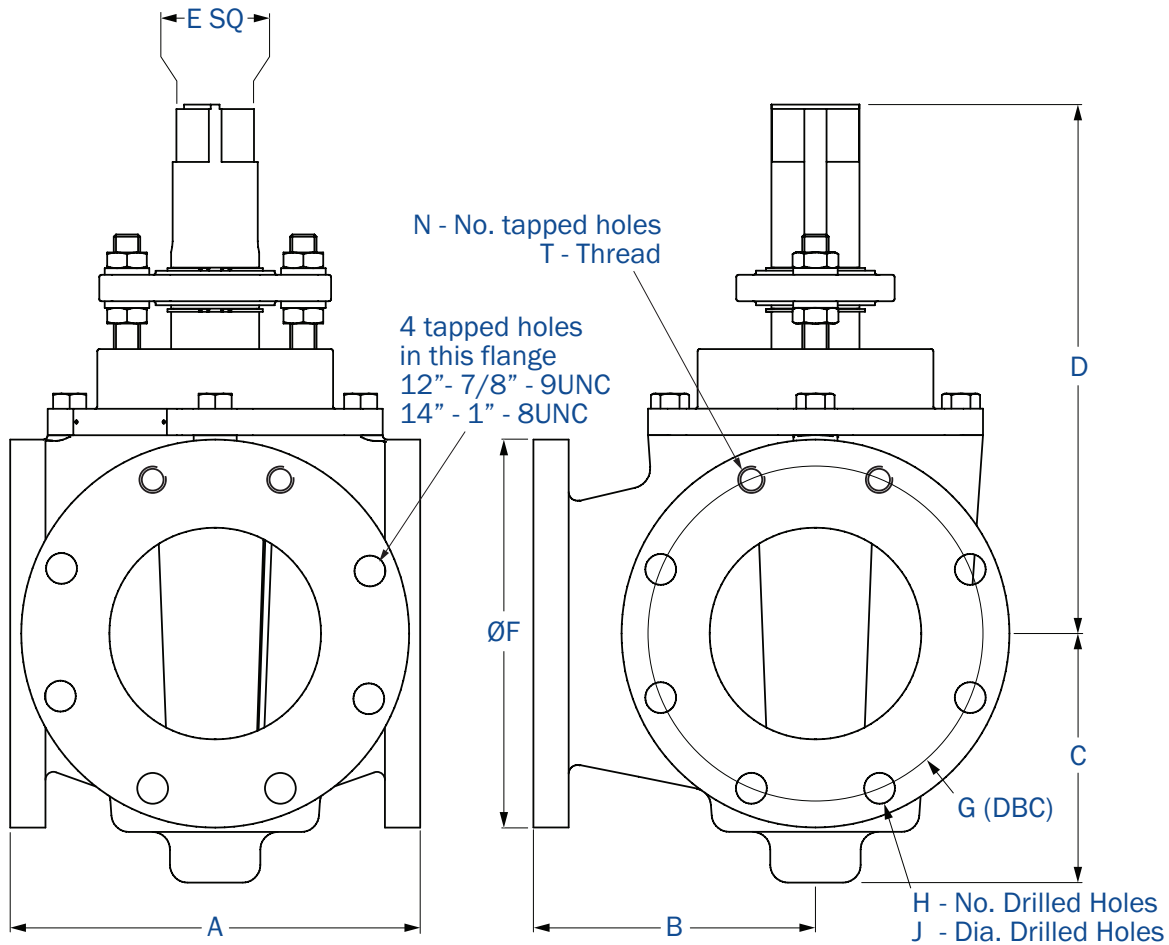

**Flanged End - Fig. 604 - Class 125**

Dimensions	Nominal Valve Size							
	3"	4"	6"	8"	10"	12"	14"	16"
A	8	9.88	11.63	13.88	16.75	19	21	23.75
B	5.5	6.5	8	9	11	11.56	12.5	15.13
C	4.81	5.94	7.06	10.94	10.94	12.88	14.19	14.75
D	9.04	13.36	15.04	18.69	18.69	21.20	21.10	22.00
E	1*	2	2	2	2	2	2	2
F	7.50	9.00	11.00	13.50	16.00	19.00	21.00	23.50
G	6.00	7.50	9.50	11.75	14.25	17.00	18.75	21.25
H	4	6	6	4	12	12	10	16
J	0.75	0.75	0.88	0.88	1	1	1.13	1.13
N	-	2	2	4	-	-	2	-
T	-	5/8" - 11 UNC	3/4" - 10 UNC	3/4" - 10 UNC	-	-	1" - 8 UNC	-
Weight - lb	65	120	170	325	380	475	850	970

**Note:** Drawings are for information purposes only; please request certified drawings before preparing piping drawings.

\* Adaptor available to convert to 2" Nut.

## Series 604AGHW Millcentric® 100% Port 3-Way Plug Valve

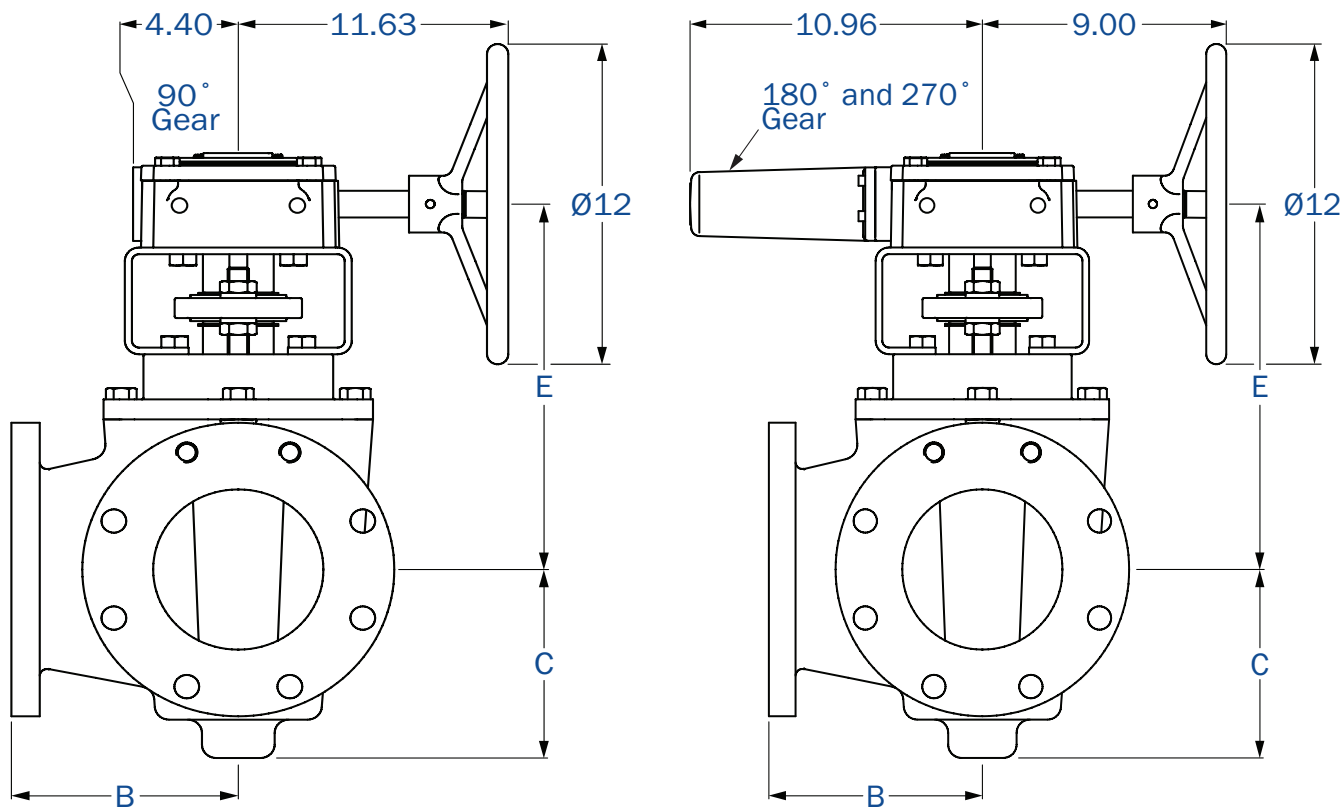

Flanged End - Fig. 604AGHW - Class 125							
Dimensions in	Nominal Valve Size						
	4"	6"	8"	10"	12"	14"	16"
A*	9.88	11.63	13.88	16.75	19	21	23.75
B	6.50	8	9	11	11.56	12.50	15.13
C	5.94	7.06	10.94	10.94	12.88	14.19	14.75
E	12.94	14.06	17.75	17.75	19.50	20.38	21.06
Weight - lb	200	250	405	460	555	937	1053

**Note:** 3" gear operated valve details upon request.

Drawings are for information purposes only; please request certified drawings before preparing piping drawings.

\* Face to face dimension and flange drilling see page 5.



## Accessories

### Wrench

Wrench operators are available for all sizes (for tight shut-off, we recommend the use of a gear operator).

### Power operation

Pneumatic, electric and hydraulic operation is available, complete with limit switches and solenoid valves when required.

### Styling Ring (for wrench operated valves)

The valve may be ordered with the plug positions pre-set at the factory to suit the port flow requirements. This is achieved by fitting a styling ring to the valve stem.

### Gear operators

Gear operators are available for all sizes.

They can be provided with 90°, 180° or 270° travel and are fitted with travel stops. 360° travel is also available.

### Locking device

Factory fitted locking devices are available for wrench operated and gear operated valves.

### Double-style plug

To provide 90° flow paths only, a double-style plug is available which operates through 90° travel and isolates either straight-through port (Style A90 only).

### Styling Ring



### Gear Operator



Shown with 180°/270° Gear



# 3-Way Valve Port Positions

## Port Positions Viewed from Above

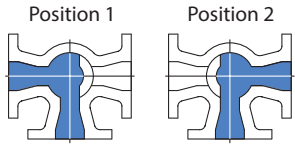

3 way, 3 port, 180° turn  
**Style A180**

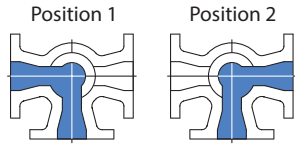

3 way, 2 port, 90° turn  
**Style A90\***

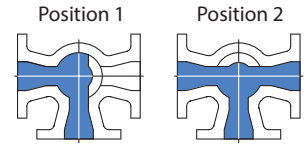

3 way, 3 port, 90° turn  
**Style C**

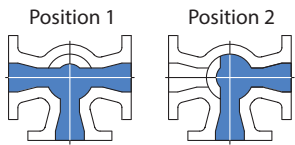

3 way, 3 port, 90° turn  
**Style D**

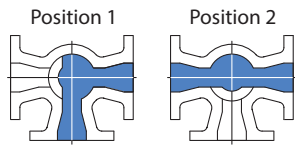

3 way, 3 port, 90° turn  
**Style E**

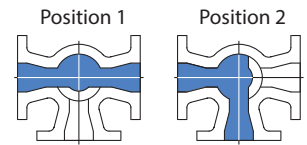

3 way, 3 port, 90° turn  
**Style F**

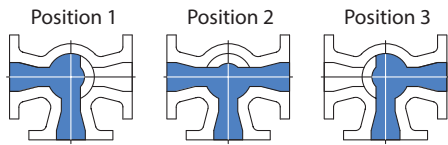

3 way, 3 port, 180° turn  
**Style G**

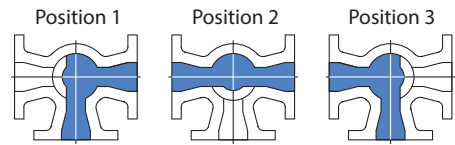

3 way, 3 port, 180° turn  
**Style H**

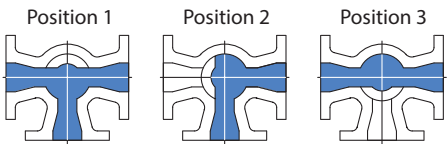

3 way, 3 port, 180° turn  
**Style I**

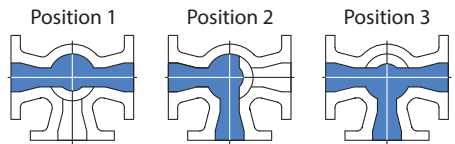

3 way, 3 port, 180° turn  
**Style J**

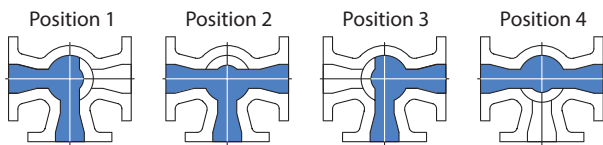

3 way, 3 port, 270° turn  
**Style K**

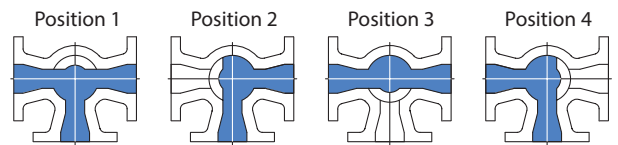

3 way, 3 port, 270° turn  
**Style L**

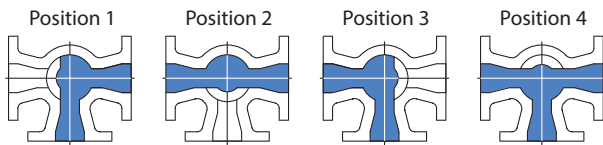

3 way, 3 port, 270° turn  
**Style M**

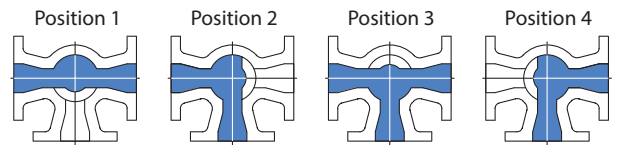

3 way, 3 port, 270° turn  
**Style N**

\*Requires Double-Style Plug. Not tight shut-off. Consult factory for special pricing and availability.

### HOW TO ORDER

When ordering 3-Way Valves, specify style letter of the port position required.

# Technical Specification

## Millcentric® 100% Port 3-Way Plug Valves

Valves shall be of the 100% Port 3-Way non-lubricated concentric type with a totally encapsulated plug. The elastomer shall be suitable for the service intended.

Valve flanges shall comply with ASME/ANSI B16.1 Class 125, including facing, drilling and thickness. Valves shall be designed for a maximum working pressure of 175 CWP.

The valve body and bonnet shall be in cast iron to ASTM A126 Class B and the plug shall be ductile iron to ASTM A536 Grade 65-45-12. The axial position of the plug shall be held by the adjustable gland, and the valve shall operate without the need to lift the plug prior to turning.

Replaceable sleeve-type bearings, manufactured in oil-impregnated stainless steel shall be fitted in the body and bonnet. Stem seals shall be self-adjusting U-cup type and be replaceable without removing the bonnet from the valve.

The valve stem shall be provided with a 2" square nut for use with removable levers or extended T-handles. Wrench operated valves shall be capable of being converted to gear or automated operation without removing the bonnet from the valve.









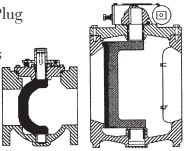
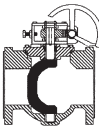
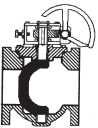
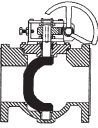
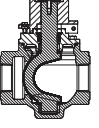
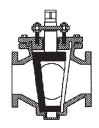

Where required, gear operators shall be of heavy duty construction with a ductile iron quadrant supported by upper and lower oil-impregnated bronze bearings. The worm gear and shaft shall be manufactured in hardened steel and run in high efficiency roller bearings. Gear operators shall require single handwheel operation only.

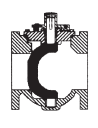
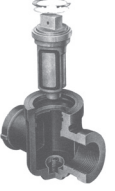
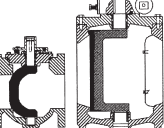
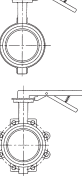
100% Port 3-Way plug valves shall be Millcentric Series 604.

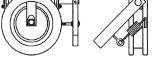

# Notes

# Milliken® Products Guide

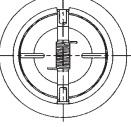
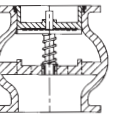
<p><b>Series 600/601</b> Eccentric Plug Valve</p> <p>Welded Nickel Seat Stainless Steel Bearings ANSI-B16.1 Flanges Solid Ductile Iron Plug Low Pressure Drop Flanged &amp; MJ Ends Sizes 2"-72" FL Sizes 3"-48" MJ</p> <p>Flanged and MJ</p> 	<p><b>Series 601SS</b> Eccentric Plug Valve</p> <p>Integral Stainless Seat Stainless Steel Bearings Stainless Steel Body ANSI B16.5 Class 150 Flanges Solid Stainless Steel Plug Low Pressure Drop Size: 1/2"-24"</p> 	<p><b>Series 601RL</b> Eccentric Plug Valve</p> <p>Soft or Hard Rubber Lining Stainless Steel Bearings ANSI B16.1 Flanges Solid Ductile Iron Plug Low Pressure Drop Sizes 3"-54" Metal Plugs Available - Consult Factory</p> <p>Rubber Lined</p> 	<p><b>Series 602</b> Eccentric Plug Valve</p> <p>Welded Nickel Seat Stainless Steel Bearings ANSI B16.1 Class 250 Flanges Solid Ductile Iron Plug Low Pressure Drop Sizes 2-1/2"-54"</p> <p>High Pressure</p> 
<p><b>Series 613A</b> Eccentric Plug Valve</p> <p>Ductile Iron Construction Round Port Stainless Steel Bearings Low Pressure Drop Memory Stop NPT End Connections Sizes 1/2"-2"</p> <p>Threaded End</p> 	<p><b>Series 604E</b> Eccentric Plug Valve</p> <p>Epoxy Seat Solid Ductile Iron Plug Stainless Steel Bearings Low Pressure Drop Lift &amp; Turn NOT Required High Solids &amp; Flow Capacity Sizes 3"-16"</p> <p>Three Way Valve</p> 	<p><b>Series 606</b> Eccentric Plug Valve</p> <p>Welded Nickel Seat Stainless Steel Bearings AWWA C-606 Grooved Solid Ductile Iron Plug Low Pressure Drop Ductile or Steel Pipe Sizes 3"-24"</p> <p>Grooved End</p> 	<p><b>Series 611/610</b> Eccentric Plug Valve</p> <p>Ductile Iron Body ANSI B16.1 Flanges MJ AWWA C111 Welded Nickel Seat Solid Ductile Iron Plug Low Pressure Drop Sizes 2"-72" FL Sizes 3"-48" MJ</p> <p>Flanged and MJ</p> 
<p><b>Model 625</b> Eccentric Plug Valve</p> <p>Available in Threaded and Flanged Ends Rated for 175 psi Sizes 1/2"-4" UL/CGA Listed</p> 	<p><b>Series 600FP/601FP</b> Eccentric Plug Valve</p> <p>Full/100% PORT Welded Nickel Seat Stainless Steel Bearings ANSI-B16.1 Flanges Solid Ductile Iron Plug Low Pressure Drop Flanged &amp; MJ Ends Sizes 2"-48" FL Sizes 3"-48" MJ</p> 	<p><b>Figure 396/397</b> General Service Butterfly Valve</p> <p>Meets MSS SP 67 Ductile Iron Body DI-NP Disc Other Materials Upon Request Wrench or Gear Operated Available 2"-48" Size Range</p> 	<p><b>Figure 510A/511A</b> AWWA Butterfly Valve</p> <p>Complies with AWWA C-504 Class 150B Flanged or MJ Cast iron body and disc Seat in body Flow through disc on 24" and larger Epoxy Paint on all sizes standard 3" -72"</p> 
<p><b>Series 8500</b> AWWA Swing Check</p> <p>Full waterway Ductile Iron Construction Weight or Spring Air Cushion SS body seat ring Buna disc insert Sizes 3"-24"</p> 	<p><b>Series 8000</b> AWWA Swing Check</p> <p>Full waterway Weight or Spring Bronze/SS Body Seat Ring Bronze/Buna/EPDM disc insert Sizes 2"-36"</p> 	<p><b>Series 9000</b> AWWA Swing Check</p> <p>Clear waterway Weight or Spring Air or Oil Cushion Bronze/SS Body seat ring Bronze/Buna/EPDM disc insert Sizes 3"-72"</p> 	<p><b>Model 720A</b> Wafer Check Valve</p> <p>Center Guided Check Valve Rated for 250 psi SS Disc/EPDM Seat Sizes 2"-12"</p> 
<p><b>Series 700</b> Wafer Check Valve</p> <p>ANSI Class 125/150 High Flow Capacity Narrow Face-to-Face Sizes 3"-12" 316 SS Internals Disc Position Indicator</p> <p>Wafer Check Valve</p> 	<p><b>Figure 851</b> Flex Check</p> <p>Million Cycle Certification Complete Ductile Iron Construction 250 psi Pressure Rating Fully Epoxy Lined Interior No Internal Shafts, Bearings or Bushings No External Levers, Weights or Springs Mechanical Indicator (3"-16") 2"-24" Size Range Backflush Devices Proximity Switches</p> 	<p><b>Figure 740A</b> Double Disc Check Valve</p> <p>Wafer pattern check valve rated for 250 psi. Available in sizes 2"-36" with a SS Disc/EPDM Seat</p> 	<p><b>Figure 821A</b> Globe Style Check Valve</p> <p>Center guided check valve. SS Disc/EPDM Seat and is available in sizes 2"-24".</p> 

The trademarks, logos and service marks displayed in this document herein are the property of Henry Pratt Company, LLC, its affiliates or other third parties. Products above marked with a section symbol (§) are subject to patents or patent applications. For details, visit [www.mwppat.com](http://www.mwppat.com). Copyright © 2016 Henry Pratt Company, LLC. All Rights Reserved.

# MILLIKEN®

# Mueller Co.

Reliable Connections™