

Midget Air Release Valves

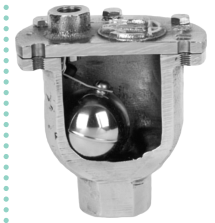

M SERIES

Midget Air Release Valves

Valve Function

- Vents trapped air in hot water systems
- Vents air from cold water, petroleum products and many other liquids with varying specific gravities
- Ideal for automatic priming of Vacuum Primed Pumps
- Meets AWWA C-512

With Stainless Steel Trim Standard

Crispin Midget Air Valves are chosen for use in venting trapped air in hot water systems by being installed at the high points of the line, thereby resulting in an increase of the B.T.U. output. The Crispin Midget Air Valve is equally well designed for venting air from cold water, petroleum products and many other liquids of varying specific gravities. The Midget is also ideal for automatic priming of vacuum primed pumps. A vacuum check is available, if desired, for attachment to the valve outlet to prevent air from re-entering the system.

All Crispin Valves are hydrostatically tested at 150% of their maximum working pressure.

Midget Valve Parts List

PART NO.	ITEM	MATERIAL	QTY/UNIT
1	VALVE SEAT	Stainless Steel	1
2	PLUNGER BUTTON	Viton	1
4	VALVE LEVER	Stainless Steel	1
5	SCREW (DRIVE)	Stainless Steel	1
6	BALL FLOAT	Stainless Steel	1
7	HINGE PIN	Stainless Steel	1
7A	PIN CLIP	Stainless Steel	1
8	HINGE BUTT	Stainless Steel	1
9	BOLT	Steel	6
10	SCREW	Stainless Steel	1
11	FLANGE	Cast Iron	1
12	BODY	Cast Iron	1
13	FLANGE GASKET	Armstrong	1
14N*	NIPPLE	Steel	1
14V*	VACUUM CHECK VALVE	Brass	1

*14N and 14V are optional at customer's request

Orifice Sizing Information

ORIFICE DIA.	MAX WORKING PRESSURE
5/32"	40 PSIG
1/8"	50 PSIG
3/32"	85 PSIG
1/16"	150 PSIG
3/64"	200 PSIG
1/32"	300 PSIG

Note: Materials and Prices Subject to Change Without Notice



Model Information

Valve Inlet	3/8"	1/2"	3/4"	1"
Model No.	M3	M5	M8	M10
NPT-Outlet	3/8"	3/8"	3/8"	3/8"
Height	5 9/16"	5 9/16"	5 9/16"	5 9/16"
Width	5"	5"	5"	5"
Weight	6lbs	7lbs	7lbs	8lbs



SUBMITTAL SHEET FOR M SERIES

Submittal Sheet for Crispin M Series

3/8"–1" Pressure Air Release Midget

Manufactured in compliance with ANSI/AWWA C512

Date: 2016

Orifice Options

DIAMETER	MAX. PRESSURE	DISCHARGE RATE
5/32	40 PSIG	12.6 SCFM
1/8	50 PSIG	9.6 SCFM
3/32	85 PSIG	8.3 SCFM
1/16	150 PSIG	6.1 SCFM
3/64	200 PSIG	4.5 SCFM
1/32	300 PSIG	3.2 SCFM

Specifications

The valve(s) shall be installed at high points in the line to vent the accumulation of air and other gases with the line under pressure.

The valve(s) shall have a _____" orifice with valve sealing faces of stainless steel and Buna-N rubber, and shall operate at _____ PSIG. Valves which use a needle valve to seal the orifice shall not be acceptable.

The valve(s) shall be Crispin-Multiplex Model _____ Midget Air Valve(s) as manufactured by Multiplex Manufacturing Co., Berwick, PA.

Valve construction shall be _____" NPT screwed, cast iron body and top flange with stainless steel float and trim.

Option: Where pressures are greater than 300 PSIG, the valve(s) shall be _____ NPT" inlet connection, and shall have a (steel, stainless steel, or ductile iron) body, top and inlet flange.

Standard operating pressure for Crispin Air Valves is 20 to 150 PSIG. Please check one of the following if your operating needs differ:

_____ 2 to 40 PSIG _____ 151 to 300 PSIG

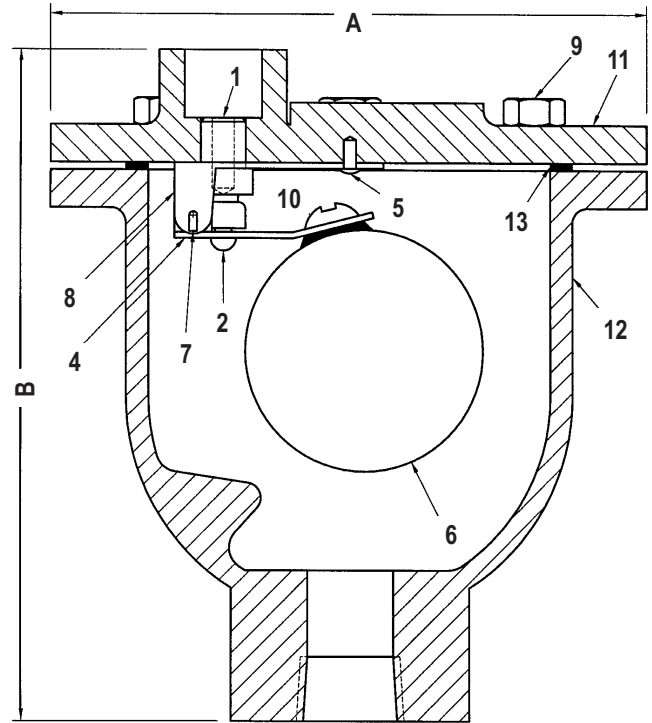

Parts List

ITEM	DESCRIPTION	MATERIAL	ASTM
1	VALVE SEAT	STAINLESS STEEL	A582
2	PLUNGER BUTTON	VITON	D2000
4	VALVE LEVER	STAINLESS STEEL	A240
5	SCREW (DRIVE)	STAINLESS STEEL	A193
6	BALL FLOAT	STAINLESS STEEL	A240
7	HINGE PIN	STAINLESS STEEL	A313
8	HINGE BUTT	STAINLESS STEEL	A240
9	BOLT	STEEL	A307
10	SCREW	STAINLESS STEEL	A193
11	FLANGE	CAST IRON	A126 CL.B
12	BODY	CAST IRON	A126 CL.B
13	FLANGE GASKET	ARMSTRONG N-8092	N/A
29	PLUG (NOT SHOWN)	BRASS	B505

Size Specifications

MODEL	INLET SIZE	OUTLET SIZE	A	B	WHT.
M3	3/8" NPT	3/8" NPT	5.00	5.75	6
M5	1/2" NPT	3/8" NPT	5.00	5.75	7
M8	3/4" NPT	3/8" NPT	5.00	5.75	7
M10	1" NPT	3/8" NPT	5.00	5.75	8